



HPCN TTN CAPRICE
ESPRIT-Project 26432

DEMOMETER

Demonstration of Parallel CFD-Methods
for
Flow Meter Designs



PUBLIC FINAL REPORT

October 31, 1999

Table of Contents

1. Synopsis.....	5
2. Executive Summary	7
3. Full Technical Text	9
3.1. State of the Art	9
3.2. Approach	9
3.3. Results, Achievements and Benefits.....	16
3.4. Dissemination	19
3.5. Conclusions.....	21

Acronyms:

ASME	American society of mechanical engineers
BATTELLE	Battelle Ingenieurtechnik GmbH
CFD	Computational fluid dynamics
COMET	Computational Mechanics Engineering Tool
DIN	Deutsche Industrie-Norm
DLR	Deutsches Zentrum für Luft- und Raumfahrt e. V.
DSA	DSA Schweißtechnik und Apparatebau GmbH
ETM	EDV-Technik Mühlgassner GmbH
HPC	High Performance Computing
ICCM	Institute of Computational Continuum Mechanics GmbH
ISA	Industry Standard Architecture
MEDEVA	Flow M eter D esign and E valuation
MPI	Message Passing Interface
OSA	Off-standard application
PVM	Parallel virtual machine
SME	Small and middle sized enterprises
TCL	Tool Command Language
TK	Tool Kit
VDE	Verband der Elektrotechnik, Elektronik, Informationstechnik e.V.
VDI	Verein Deutscher Ingenieure

HPCN TTN CAPRICE



DEMOMETER – Esprit 26432

Demonstration of Parallel CFD-Methods
for
Flow Meter Designs

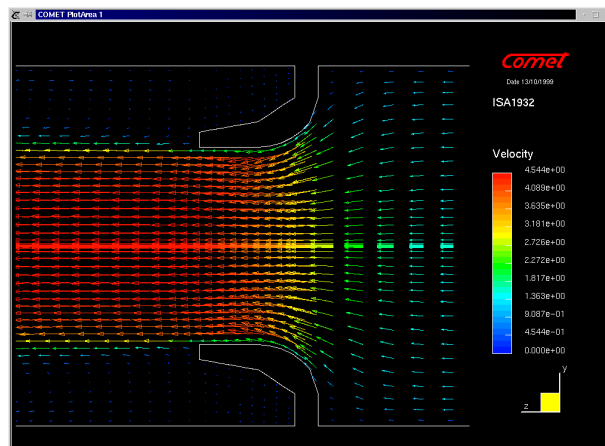

Medeva

Flow Meter Design and Evaluation

This product is subject to a licence agreement
with Battelle Ingenieurtechnik GmbH

<http://www.battelle.de/frames/TechnischeSoftware.htm>

1. Synopsis

Abstract

Flow meters with restriction areas are commonly used in power plants and chemical industry to evaluate mass flow inside piping systems. Straight inlet before and outlet pipe lengths after these devices are required to meet the measurement accuracy according to regulations (DIN, VDI/VDE, ASME). As requirements can often not be met flow devices could not be implemented or they were operated at low accuracy. Three-dimensional calculations including all relevant geometric details are essential for design of flow devices under off-standard conditions. CFD-methods for this specific purpose require HPC. A Parallel simulation program has been developed and successfully demonstrated in this project.

Detailed knowledge in fluid dynamics and applied computer science is still necessary to operate these tools properly. The skill, methods and hardware requirements are usually not met by SMEs involved in production process. The final product "MEDEVA" of this project improves this situation and can be applied successfully by the operational personnel.

An existing CFD program has been migrated to a low cost parallel platform. The program has been installed and customised, following users requirements. The user has integrated the customised tool in his production process.

Project timescale

The DEMOMETER project started in November 1997 and ended in September 1999. The whole duration of the project was therefore 23 month.

Costs and EC contribution

The global cost of the project was *362.400 Euro*, the European Commission has funded *184.600 Euro* through the Esprit initiative. The remaining resources have been funded by the project partners.

Keywords

Flow meter, flow measurement, parallel computing, CFD, MPI, PC-cluster, fluid mechanics, DEMOMETER, MEDEVA, LINUX.

Contact details

The following table summarizes the contact persons of the DEMOMETER project:

 <p>DSA Apparatebau und Schweißtechnik GmbH</p>	<p>Dipl Ing. Rainer Schulz Rathenaustraße 23 D-63263 Neu-Isenburg Tel.: +49(0)6102/702811 Fax: +49(0)6102/702819 email: schulz.r@t-online.de</p>
 <p>Ingenieurtechnik GmbH http://www.battelle.de</p>	<p>Aron Kneer Düsseldorfer Str. 9 D-65760 Eschborn Tel.: +49(0)6196/936-313 Fax: +49(0)6196/936-399 email: akneer@battelle.de</p>
 <p>http://www.etm.at</p>	<p>Klaus Jandl ETM AG Kasernenstr. 29 A-7000 Eisenstadt Tel. +43 2682 741-0 Fax: +43 2682 741-107 email: jandl@etm.at</p>
 <p>Deutsche Luft- und Raumfahrt TTN-CAPRICE http://www.ibr.cs.tu-bs.de/projects/caprice</p>	<p>Norbert Döler TTN CAPRICE c/o DLR Linienthalplatz 7 D-38108 Braunschweig Tel.: +49(0)531/295-2140 Fax: +49(0)531/295-2767 email: etc.caprice@dir.de</p>

2. Executive Summary

Flow meters are widely employed in the flow lines of power and chemical processing plants. Specifications are defined by large mass flow rates and high accuracy requirements. Within the European market, approximately 50 enterprises achieve a total market volume of 75 Millions of Euro.

Vendors of flow meters must promptly answer inquiries for off-standard applications (OSA) which are beyond the limits of customary CFD standards. Numerical methods, suitable for problem solution, demand HPC technology, which is generally not available to SMEs.

Development of a fully parameterised and customised parallel CFD-program for the design and specification of flow meters for OSA has been proposed (figure 1). A low cost parallel demonstrator together with the tailored application is installed at the industrial end user. Little expert knowledge will suffice for proper program operation.

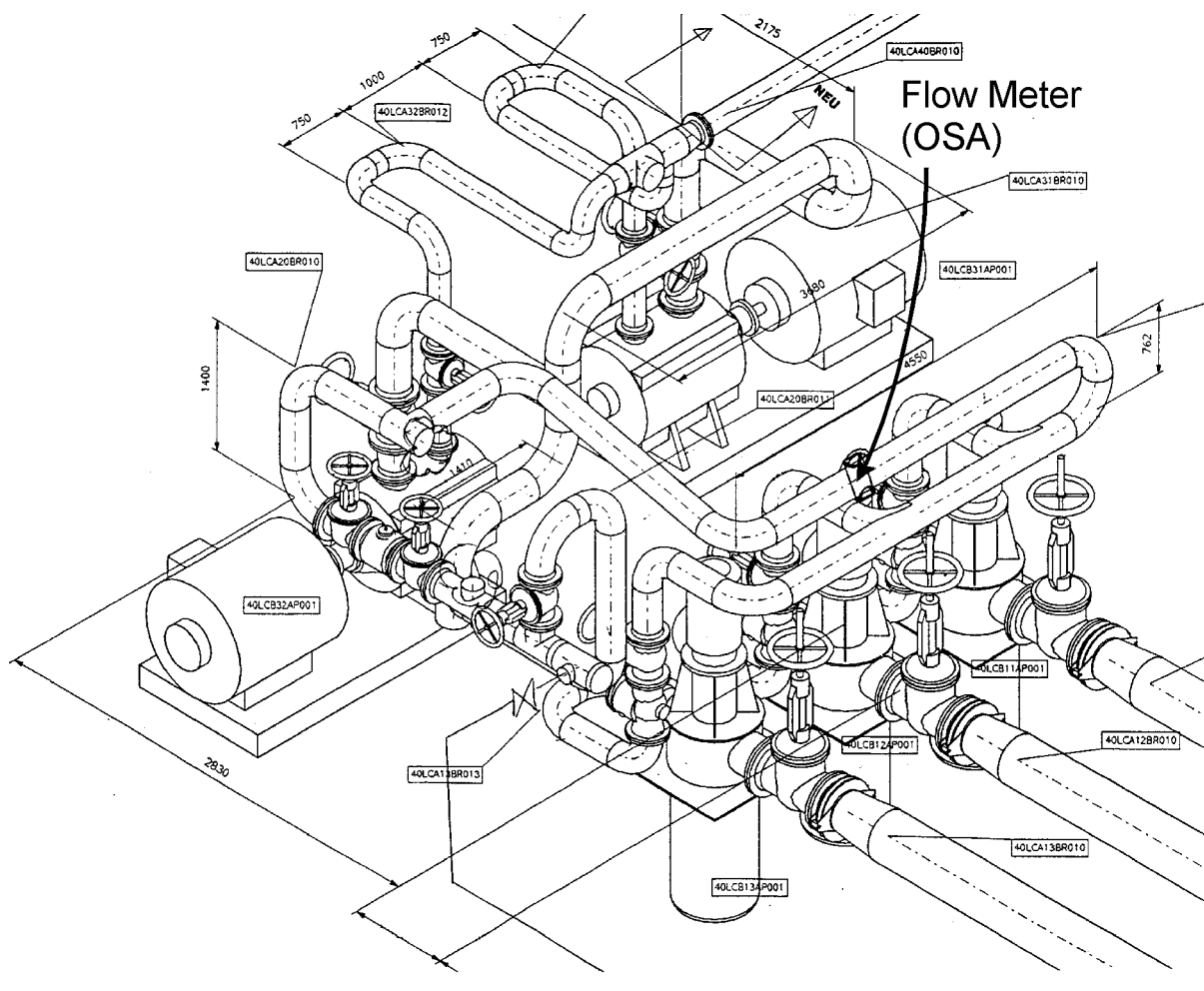

Figure 1: Typical off-standard application

Independent of national standards, the meter vendor is brought into a position to select the ideal metering device for a specific off-standard application. Therefore accuracy of the measurement method is improved. The design phase of flow devices is reduced, strengthening the vendors market position. The design process is shown in figure 2.

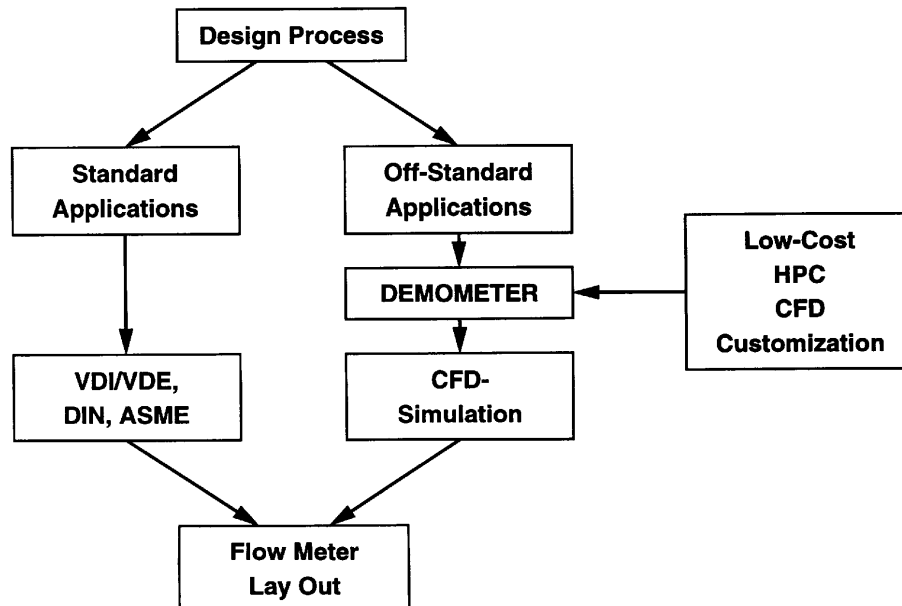

Figure 2: Design process

New market segments will be opened since OSA can be treated and implementation of new flow devices are possible. The appearance of the new technology on the international market enforces the execution of different national standards. They impose distinct constraints on the vendors. The strategy developed in this project is of general interest for the "flow-meter-manufacturer-community".

In a similar manner, analogous methodology can be adopted to different industrial sectors, where comparable, periodic and customisable HPC applications can be employed by manufacturers.

DSA Apparatebau und Schweißtechnik GmbH manufactures flow metering devices. DSA defined industrial users requirements, contributed an application of practical importance, took part in evaluation and assumed responsibility for evaluation report.

Battelle as technology provider migrated an existing numerical CFD program to a low-cost parallel platform. The program has been customised following users requirements.

DLR is the manager of TTN CAPRICE and will use the existing communication channels to disseminate and exploit the project results via the network of TTNs as well as outside of this network to the target market.

ETM has successfully implemented parallel applications for process control and visualisation from UNIX to Windows NT. They contributed expert knowledge for prompt prototyping.

3. Full Technical Text

3.1. State of the Art

Small and middle sized enterprises (SME) producing flow meters do not have in general enough time to integrate state of the art parallel CFD-technology into their day by day production process. The reasons are simple. Investigations in hard- and software and also in education need to be done to get those new techniques integrated in the working environment. CFD-tools are not easy to use, geometric models need to be meshed, codes have to be run and results have to be evaluated. Also expensive hardware have to be bought to get those tools run within a specific time frame. HPC-methods are not yet known and are too complicated to use for the non-experts. Serial calculations need too much time, the response time is too long.

There is a clear need for “simple” methods to get flow devices modeled, calculated and evaluated. DEMOMETER is the answer to those users requirements. MEDEVA (Flow Meter Design and Evaluation) has especially been realized for those kind of flow simulations. A TKL/TCL based users interface to the commercial parallel CFD-tool COMET has been produced. It has been customized to users requirements with the aim to equip an engineer without special knowledge in CFD-technology with an powerful parallel CFD-tool, simple and efficient to use.

MEDEVA reduces considerably the effort for mesh generation of complex three-dimensional isometries, flow devices like orifices, ISA-nozzles or venturies included in pipelines. An integrated property database gives the right values of the selected fluid properties in dependence of pressure and temperature. Parallel features are reduced to a simple selection of hosts. Domain decompositions for parallel calculations is automatically performed by MEDEVA. Job execution, job control and results evaluation has been realized in an user friendly way. The modeling phase can be reduced from hours to minutes. Using any PC's in the network for the calculations reduces the simulation time due to acceptable needs. Low-cost platform can easily be extended by any PC from the actual market. The HPC-platform therefore is attractive in price and efficiency.

3.2. Approach

DEMOMETER is a typical demonstration project. Each partner played its important role in the project. Originally it was not intended to get a product out of this project. But during the project soon it was clear, that the customized CFD-tool can be a tool with aspects. The main topics of the project are:

1. User requirements
2. Selection of a multi purpose parallel CFD-tool and Pre- Postprocessor
3. The graphical users interface MEDEVA to COMET
4. Building up a cluster of PC's as low cost test platform
5. Integrating HPC-techniques (MPI, PVM) for the low cost platform
6. Test Cases
7. Evaluation of MEDEVA

User requirements

To insure that the industrial user will finally be able to model all those flow devices he needs for the day by day production process, in a first step the requirements for a customized parallel CFD-tool has been worked out.

This “specification” for the program developers can be seen as “handbook” for the software design. In the first phase all geometric parts which are necessary to model a piping system have been identified.

Furthermore a set of flow meters which are produced have been selected to be integrated into the graphical interface MEDEVA.

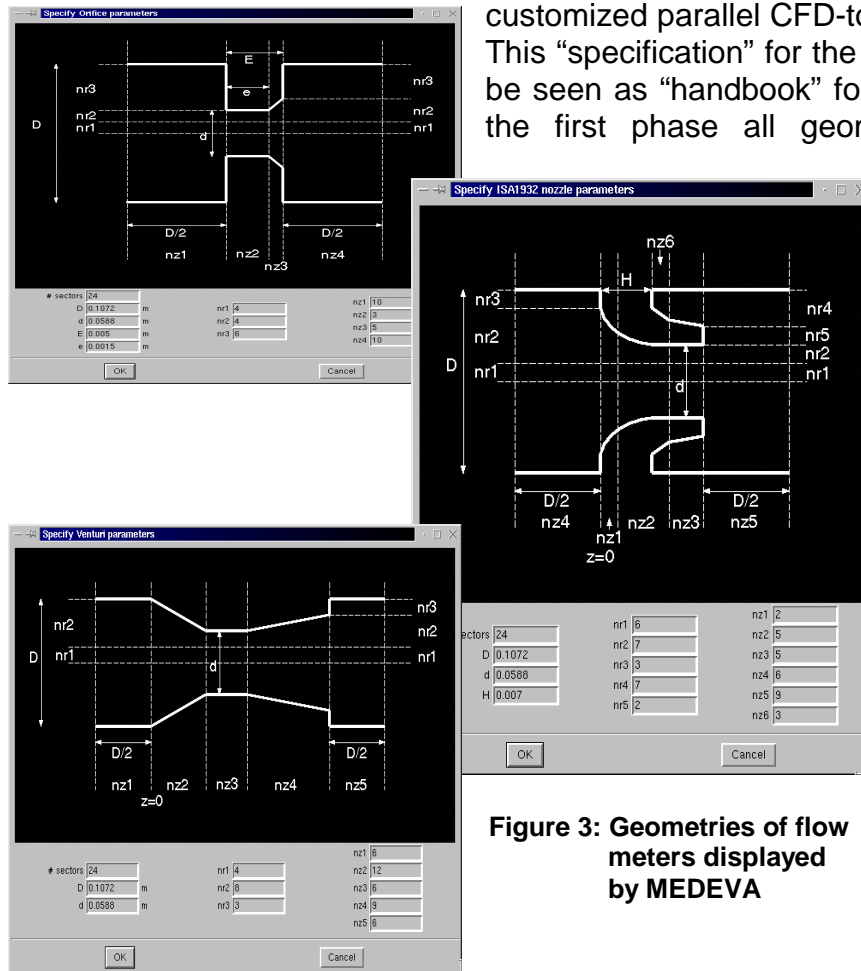

Figure 3: Geometries of flow meters displayed by MEDEVA

The following list shows all geometric base configurations which can be handled.

- Pipes, Bends
- Orifice
- Venturi
- Isa-Nozzle

These “basic” configurations can be modeled by setting some parameters like diameters, lengths etc.. The figure 3 shows the flow meters which can be modeled and which are displayed by MEDEVA. Mesh generation for those geometric entities is a question of minutes. The piping system containing somewhere a flow meter can be constructed step by step. All parameters which have to be given have been achieved by the industrial user and have then been built in. Additionally to the geometry the operation conditions need to be specified. DIN-cases are originally designed using a simple 1-D program which needs some input like mass flow, pressure, temperature etc. To insure that the user will have nearly the same input regime the values which have to be given for OSA-cases are the same. Additionally a

material database for different fluids (Vapor, water, gas) have been integrated into MEDEVA so that the properties of the fluid are automatically calculated. To specify all properties only mass flow, pressure and temperature has to be given. The other values like density, velocities at inlet etc. are calculated. In order to get easy control of running the parallel application the very detailed information when running the code is compressed due to important values like residuals which are displayed graphically. Furthermore after having run the code, results obtained can easily be displayed customized to users requirements. Pressure tapping points can be specified where at least pressure difference is measured. At these points the pressure difference can be plotted, the best point is displayed. Additionally it has been realized to get easily contour plots of obtained results for specified cuts. Summarized following requirements have been identified and realized for the graphical interfaces MEDEVA:

- Simplifying the preprocessing by automatic mesh generation for flow meters and piping systems
- Automatic calculation of fluid properties based on a steam- water database
- Automatic specification of inlet and outlet
- Easy selection of hosts for parallel run, automatic partition of mesh based on metis-library
- Industrial relevant responding times for the whole modeling phase
- Easy results evaluation
- Graphical job control for serial and parallel runs
- Simplified data handling (case oriented, cases can be named freely)
- All for OSA-calculations not relevant functions are hidden but professionals can use them

The multi purpose CFD-code COMET

Most of the commercial codes could have been selected for the DEMOMETER project because the numerical methods are nearly identical and FINITE VOLUME discretization is standard. Turbulence Models of the k-eps family are widely used and therefore the solving methods needed not to be analyzed. For the project it was important to fulfill following requirements:

- Full parallel (domain decomposition) operation
- User coding available
- Preprocessor integrated
- Batch operation of preprocessor possible
- Available on Linux, Unix and NT
- Postprocessor integrated
- Batch operation of postprocessor possible

Well it has been found that COMET and its Pre- Postprocessor Cometpp are the right tools for the project. *comet* is a multi purpose ICCM-Software for the solution of continuum mechanics problems (both fluid and solid mechanics). It is a self-contained package incorporating mathematical models of a wide range of thermo-fluids and solids phenomena, powerful solvers enabling full complex-geometry capabilities, highly efficient and stable set of numerical solution algorithms, flexible pre-processing and post-processing facilities tailored for both expert and novice users. *comet* is developed by professionals who have been at the forefront of both the research and the commercial software development in the field of computational continuum mechanics in the last 15 years. The code is based on the authors' own pioneering work in the fields of discretization by arbitrary (moving) meshes, error detection, full multigrid acceleration techniques, parallel computing and finite volume stress analysis.

Continuum mechanics is conventionally subdivided into solid mechanics and fluid mechanics and, traditionally, problems involving an interaction between fluid flow and heat transfer and resulting deformations and stresses in the solid structure in contact with the flow (heat exchangers, wind loaded structures, internal combustion engines, etc.) are treated separately, in a decoupled manner, often using completely different (analytical or numerical) solution techniques. *comet* removes such artificial barriers within continuum mechanics, offering the modelling of a very comprehensive range of physical phenomena.

The users interface MEDEVA to COMET

MEDEVA has been written in TCL/TK and EXPECT and can be used on different platforms. It handles all informations necessary for the parallel CFD-code COMET and its Pre- and Postprocessor. MEDEVA has been written with the aim to simplify and speed up the modeling phase, which normally takes a lot of time, especially for three dimensional geometries. The generation of a full model including the flow meter device and the piping system can be achieved within half an hour. MEDEVA covers thousands of COMET-commands which are compressed to a simple and userfriendly input regime. Complicated input regimes are so reduced to some mouse clicks.

The required time to run the COMET-code can easily be reduced by parallel calculations. Integrated HPC-features based on MPI and PVM can be adopted for a run by selecting hosts which are available in the network.

Figure 4: Generated Mesh

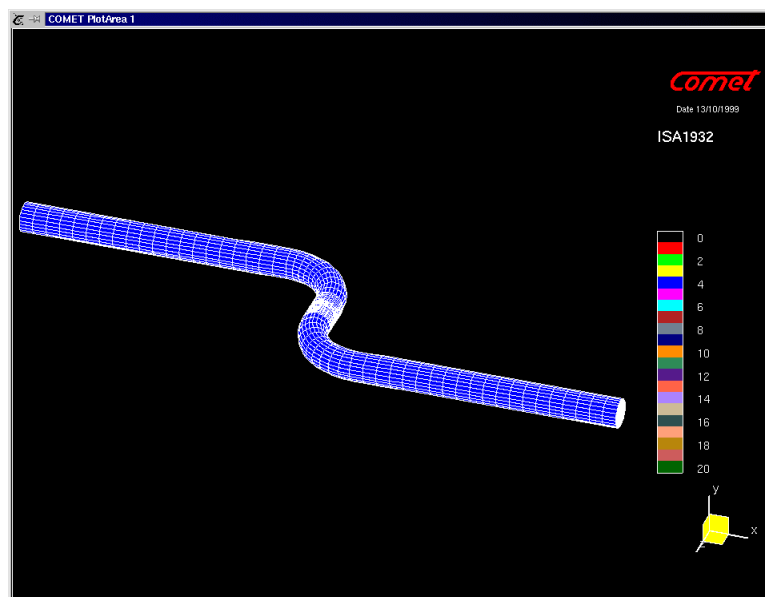
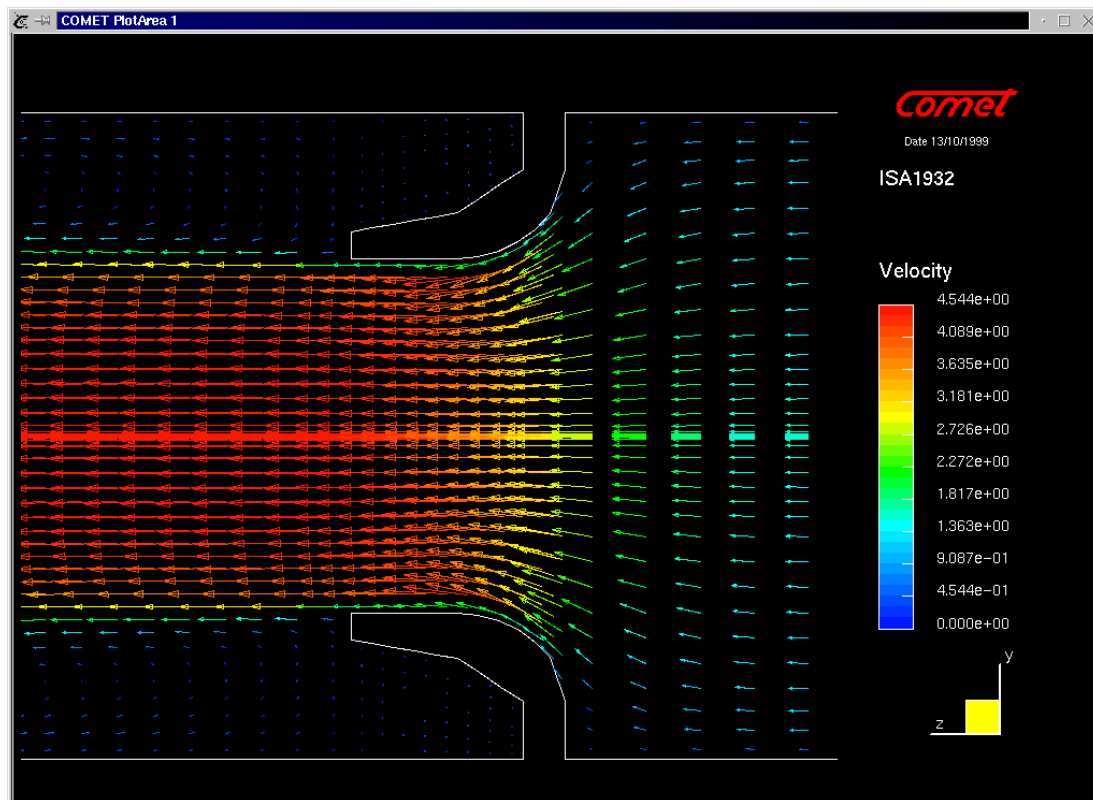

Figure 4 shows the result of the mesh generation for an ISA-nozzle. Figure 5 shows the calculated velocity distribution through the nozzle.

Figure 5: Calculated Velocity distribution



MEDEVA does not only support the user in mesh generation, it also provides powerful customized functions for postprocessing. There is no need to specify a lot of parameters to get the results displayed. Plotobject can easily defined and the selected results (velocity, pressure) is then be plotted on that plotobject.

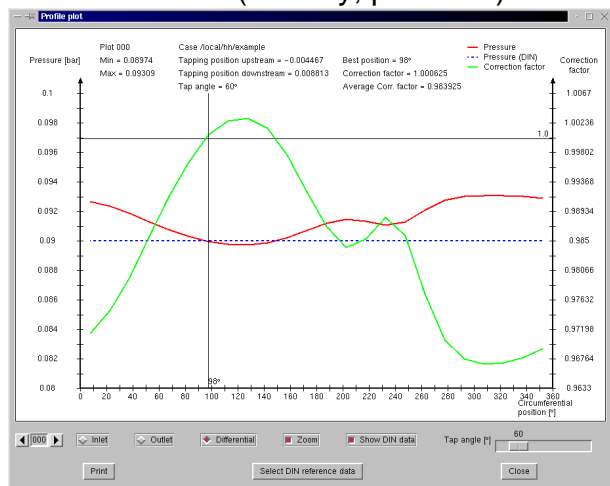

Figure 6: Result profile plot

These plotobjects are stored in the database and can be modified, deleted etc. All views can be printed or hardwired. During the day by day process special pressure tappings are of interest to be examined. Therefore MEDEVA provides the easy selection of pressure tapping points by sliders or direct given values. The pressure distribution then is given as a curve in circumferential direction. If a DIN-case has already been calculated the results achieved can be loaded into that graph and compared to the actual one (s.fig.6).

MEDEVA is a frontend tool developed for flow meter designer and is very open to insert other geometric entities. The general goal of the tool is to get very complex codes simplified. Input is reduced to typical well known parameters and the HPC-features are integrated in a way that only "hostnames" have to be given. Domain decomposition, MPI or PVM administration is then be performed automatically.

EXPECT reads and prompts all commands given or returned. The user of MEDEVA needs no specific CFD-knowledge. It can be used by selecting known geometries and specifying pre-defined fluids and operation condition. Job execution and job control is performed by MEDEVA. During the run of the code temporarily the achieved results can be displayed. Convergence criterion is shown in the graph as a horizontal line and the residuals are drawn for each iteration. The user is able to see how far the run is. Figure 7 shows this graph for a typical run.

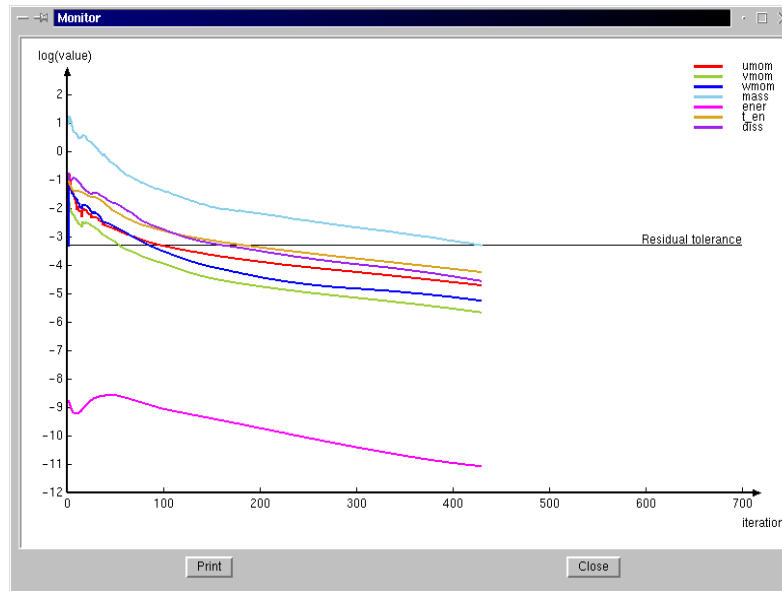

Figure 7: Online residuals graph

MEDEVA has been evaluated by the industrial partner DSA. It has been found useful and fast. Several cases have been modeled and during the whole phase contact to the technology provider Battelle as the developer of MEDEVA user requirements have been reflected.

PC-cluster for parallel applications

Running a code in parallel can only be performed if the hardware is prepared for that issue. Therefore it is necessary to install a number of tools like MPI or PVM. Also the code itself has to support any kind of parallelism. In the area of CFD-technology the standard method to parallelise a code is domain decomposition. This method can be described in the following way:

- The whole solution domain (meshed geometry) is subdivided in a number of subdomains
- Each of these subdomains is then computed by different “processors”
- These processors can be in a network of PC’s or WS
- Data at the block interface is exchanged from neighbor to neighbor processor by message passing (MPI, PVM)
- The global data like residual etc. are collected and broadcasted by one processor (master)

To demonstrate the feasibility of this method for a low cost hardware architecture a cluster of four PC's has been constructed. The connection between each PC has been organized by a 100Mbit Ethernet. MPI and PVM was installed. The CFD-tool has been installed and benchmarked on this platform. It has been found that the efficiency from one to four PC's is more then 70%. So a serial run can be speeded up by a factor of 3.8. This method is very efficient up to 8 processors.

The benefit of parallel calculations can be seen from the following example: A typical OSA model exists of about 150.000 cells. The solution procedure for such a model in serial mode takes more than 1 hour, the analogical run in parallel mode on a five PC-cluster takes less than 15 minutes.

3.3. Results, Achievements and Benefits

The main tasks of the project

- Simplified modeling and mesh generation for flow meters and the associated piping system
- Short calculation times
- Easy evaluation of the results
- Simplified data handling
- Applicable on low cost platforms

are realized as proposed.

The accurate functioning of the MEDEVA / COMET tool was evaluated with two examples of industrial off-standard applications of flow meters. As it can be seen from the pictures below, the modeled piping systems consists of straight pipes, 90-degree bends and a sharp edged orifice (fig. 8), resp. an ISA-nozzle (fig. 9).

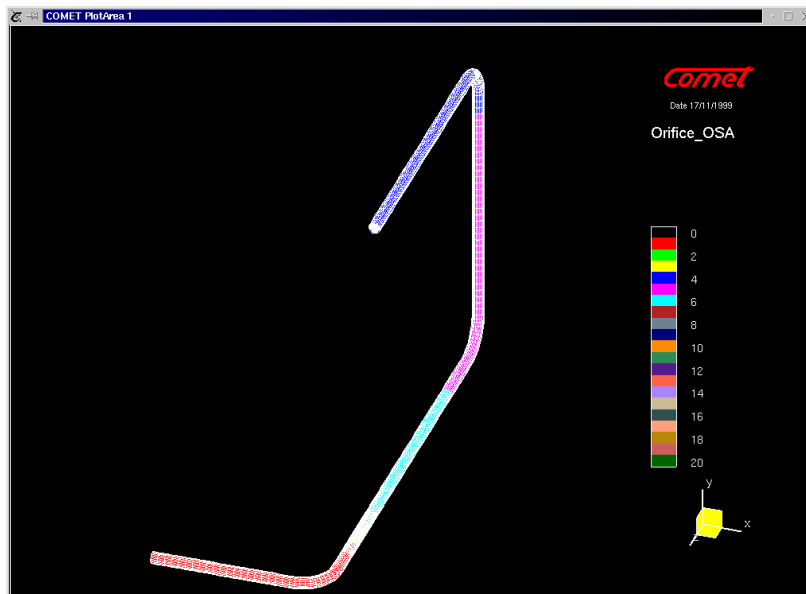

Figure 8: Example 1, Sharp edged orifice in a pipeline

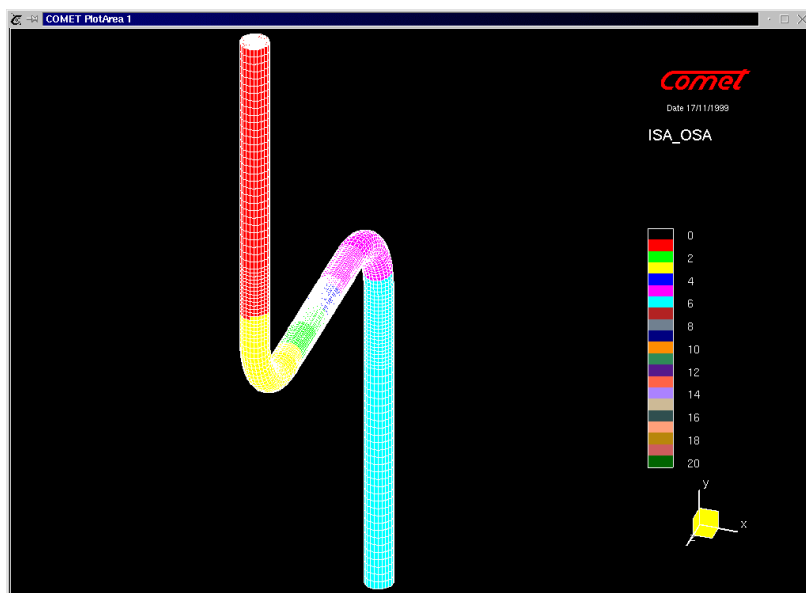
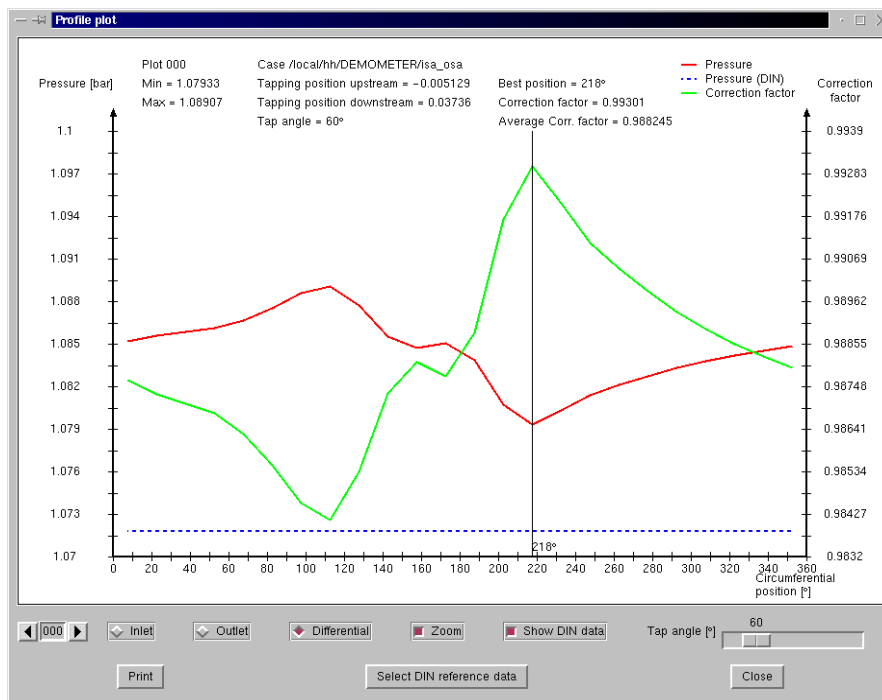

Figure 9: Example 2, ISA-nozzle in a pipe system with 2 bends

The calculation of the examples has shown, that the preparing of the input datasets and the data transfer to the COMET solver can be achieved easily and quickly with the MEDEVA pre-processor. The sequencing COMET-calculation was carried out without any numerical problems. This proves, that the predefined default control- and equation parameters are well chosen. The COMET-calculation (parallel run with five processors) took about 10 minutes to meet the convergence criteria, the results look promising.

The evaluation of the results with MEDEVA was as easy to carry out as the modeling procedure. Figure 10 shows a profile plot for the ISA-nozzle. For the comparison with DIN-data for both off-standard examples the corresponding standard cases were also calculated.



**Figure 10:
Profile plot for the
ISA-nozzle example**

After the test procedure the MEDEVA / COMET package was installed on a PC at a flow meter producer and a user training was carried out. The industrial end user performed an analysis of an OSA-case independently including modeling of the piping system, definition of the boundary conditions and fluid properties, performance of the calculation, and evaluation of the results. Since the work could be carried out without any problems, it can be stated, that even users without experience in numerical simulations can operate the MEDEVA tool properly and achieve reliable results.

As the first experiences of the industrial end user have shown, the following major benefits of the DEMOMETER project can be stated:

- Deployment of PC cluster-technology to the end user
- Deployment of an HPCN-enabled parallel CFD-simulation package specially tailored to simulate flow meters

- Deployment of a customized pre- and postprocessing tool specially tailored to user requirements
- Integration of parallel simulation technology into industrial process
- Piping systems with flow meters devices under off-standard conditions can be calculated by inexperienced code users
- Correction factors for measured data of OSA can be evaluated for further processing in the data logging
- The time exposure of the design phase can be reduced
- The vendors market position will be strengthened
- New market segments will be opened
- The strategy developed in the DEMOMETER project is of general interest for the “flow meter manufacturer community”

3.4. Dissemination

The dissemination can be grouped in three main activities:

- Presentation at exhibitions and at different opportunities
- Briefing actions
- Web presentation

In the case of presentation at exhibitions there are two exhibitions where MEDEVA has been demonstrated. These demonstrations have been performed by DLR and it has been found very interesting by a number of companies. The two exhibitions were one in Toulouse and the other at Friedrichshafen (Germany, AERO). The main benefit of these presentations are some contacts which could be used for direct exploitation activities.

Furthermore MEDEVA has been demonstrated at a number of customers and partners of Battelle. Most of these demonstrations happened during other events like project meetings and service activities. Most of the people have been interested in the tool but there was always defined a need to have the tool for testing before any decision. Therefore it has been decided to produce a CD-Rom including MEDEVA and COMET with a temporary license to send to all interested companies. In addition to the described activities the DEMOMETER project has been presented at the DIN Normenausschuß (Regulatory Board).

The briefing action which has been performed then included most of the companies producing flow meters or working in a similar area. This action is underway and the CD will be sent around. A list of twenty companies will receive it. The MEDEVA tool is prepared for running on UNIX and LINUX systems.

Finally dissemination has been performed by web presentations which has been initiated by DLR and the final webpage of DEMOMETER can be found under <http://www.ibr.cs.tu-bs.de/projects/demometer>. Furthermore a short article has been written for the German journal “CHEMIE”. The article will be presented at the beginning of December. The article written in German is shown below:

CFD leicht gemacht

Kleine und mittlere Unternehmen, die im Bereich Anlagenbau tätig sind, stehen bei der Entwicklung und Auslegung ihrer Anlagen oft unter Konkurrenzdruck. Zeit, um modernste numerische Methoden einzusetzen ist kaum vorhanden. Hohe Investitionen in die Hardware und Software Infrastruktur und eine zeitraubende Ausbildung für Spezialisten in numerischer Simulation verhindern häufig den ersten Schritt. Zur Überwindung solcher Einführungshindernisse wird hier ein Lösungsansatz, ähnlich wie bei der Variantenkonstruktion vorgestellt.

Bei der Auslegung von Durchflußmeßgeräten reichen die Regelwerke von DIN, ASME etc. bei normgerechtem Einbau aus. Sind jedoch aufgrund baulicher Gegebenheiten diese Regeln nicht einzuhalten, fehlt es an geeigneten Methoden, um diese Off-Standard-Anwendungen (OSA) effizient und mit hoher Sicherheit auszulegen.

MEDEVA (Flow Meter Design and Evaluation) ist eine eigens für diese Aufgabenstellung zugeschnittene grafische Oberfläche, mit dem Ziel einem Ingenieur ohne CFD-Spezialkenntnisse (CFD = Computational Fluid Dynamics) ein einfaches, effizientes und kostengünstiges Simulationswerkzeug zur Verfügung zu stellen. MEDEVA ist ein effizientes und robustes grafisches Benutzerinterface zu dem kommerziellen CFD-Programm COMET und bietet die Möglichkeit binnen Minuten dreidimensionale Rechengitter für Rohrleitungssysteme mit Strömungsmeßgeräten zu modellieren. Eine eingebundene Materialdatenbank sorgt für die richtigen Materialdaten für das zu simulierende Medium in Abhängigkeit von Druck und Temperatur. Für die Berechnung können bequem bereits im Netzwerk vorhandene leistungsfähige PC's eingesetzt werden. Als Ergebnis der Berechnungen können die Verteilungen von Druck, Temperatur sowie Geschwindigkeiten an beliebigen Positionen und Schnitten ausgewertet werden.

Die aufwendigen dreidimensionalen Strömungsberechnungen können so in kürzester Zeit durchgeführt werden. Der Vorteil dieser Technologie ist, daß der Auslegungsingenieur oder -techniker von der Modellerstellung bis zur Auswertung der Rechenergebnisse durch MEDEVA exakt nach seinen Bedürfnissen geführt wird und einfachste Handhabbarkeit garantiert ist. MEDEVA kann beliebig auf andere verfahrenstechnische Systeme erweitert werden.

Dissemination material like flyers, handouts, power point presentations etc. have been distributed. The production of the CD-Rom including the MEDEVA tool and COMET has been produced in such a way that the customized CFD-tool can be run from the CD-Rom without installing it on to hard disk. This is much more efficient for somebody to have a look to the features.

Following table summarizes the dissemination activities:

Action	Date	Description
Presentation		AERO exhibition
Presentation		ExhibitionToulouse
Presentation	July 1999	DIN-Normenausschuß
Presentation	June 1999	ICCM Hamburg
Presentation	June 1999	Simulog France
Presentation	December 1998	FH-Graz
Briefing	November 1999	Several companies
CDROM	November 1999	Produced
Flyer	October 1999	Produced

3.5. Conclusions

Technical goal:

As mentioned above in the technical part of this report it can be clearly stated that the technical goal to customize a parallel CFD-tool for engineers of SME's which is represented by DSA has been successfully achieved. HPC-technology and modern CFD-methods available in the MEDEVA tool has been evaluated and is used by the end user of the DEMOMETER project. It has been shown that MEDEVA is easy to use and the results are accurate. The goal to have a tool to use HPC-technology without being an expert has been reached. A tool for "everybody" working in the area of flow devices without expert knowledge in numerical methods was always the main focus of the project. Easy use, running of low cost platforms in parallel, having acceptable speed up results could be achieved.

Economical benefits:

The design of flow meters is originally performed by using tables or simple lay out tools which support the engineer in specifying the right flow meter for a given circuit. If the DIN or ASME requirements are not fulfilled there is a need to have a tool like MEDEVA. Fast response times and high efficiency in using it saves time and finally costs. Additionally the industrial producer can integrate off-standard applications in his product line. So the market is widened and new services can be marketed.

For the tool provider the customization techniques is a key solution for a number of other industrial companies which have a need in fast response time during the development of industrial products.

Exploitation plan

Battelle will actively market MEDEVA. A executable MEDEVA demonstration-CD has been produced and can be provided to potential customers. Furthermore Battelle will offer consultancy services on customisation of parallel simulation tools. Through contract research, services and simulation programs, Battelle is in permanent contact with customers and applicants. The impact of DEMOMETER on CFD technology will be demonstrated to existing and prospective clients, widening its market. Besides Battelle will contact hardware suppliers in order to cooperate in marketing parallel low-cost platforms.

By its marketing organisation, Battelle will propagate the results obtained in the project. Promotion will be further ensured by participation in workshops, presentation of results at exhibitions and by Battelles membership in industrial, commercial and scientific organisations.